

RAPID FUSION

# APOLLO AM CELL

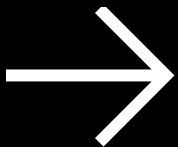
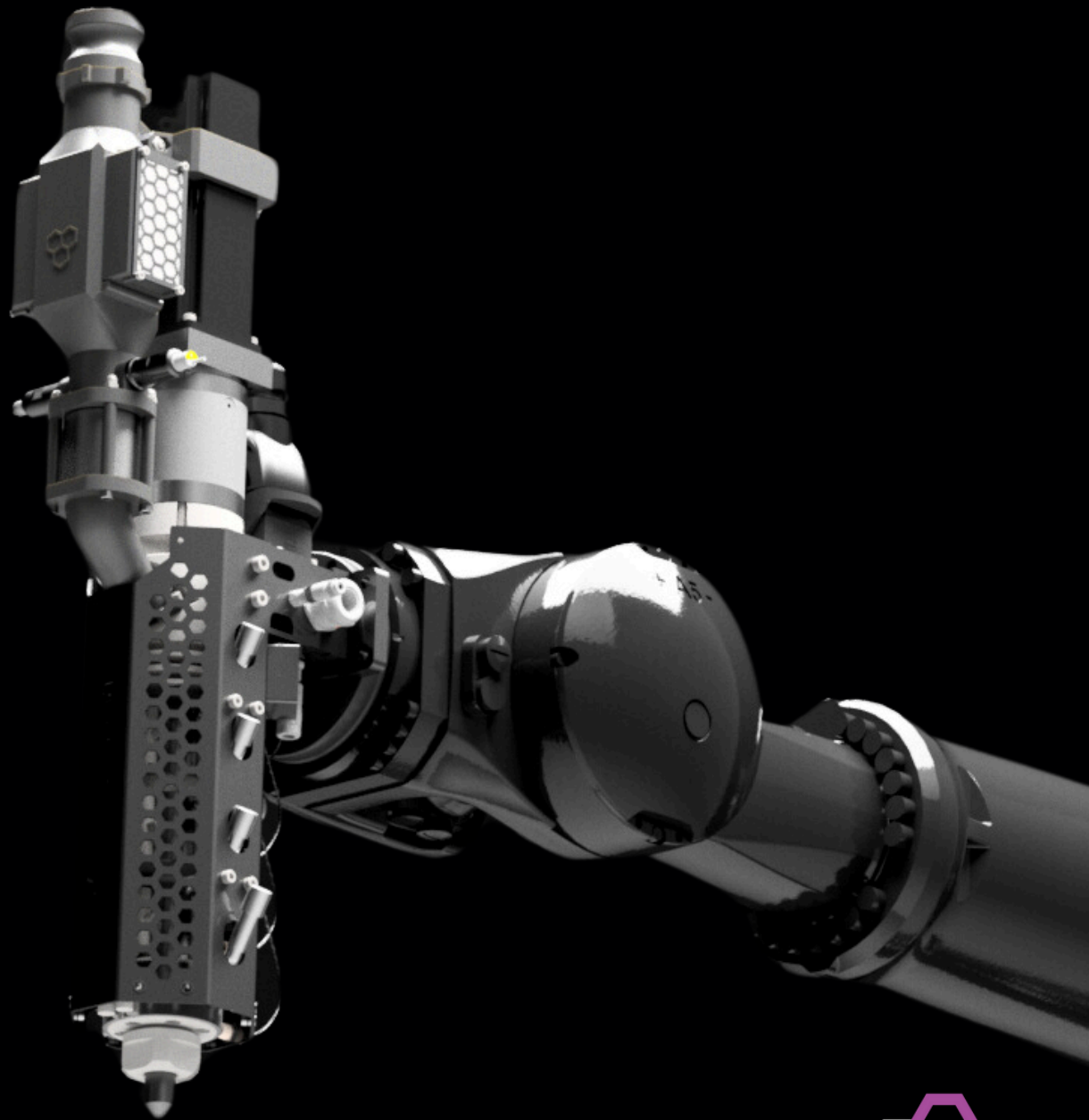

# TABLE OF CONTENTS

---

<b>01</b>	Apollo Cell
<b>02-04</b>	PE320 Pellet Extruder
<b>05-07</b>	Epicurus Controller
<b>08-09</b>	Robot Solution
<b>10</b>	Modular Heated Bed
<b>11</b>	Pellet Dryer
<b>12</b>	CAM Software
<b>13</b>	Contact

---

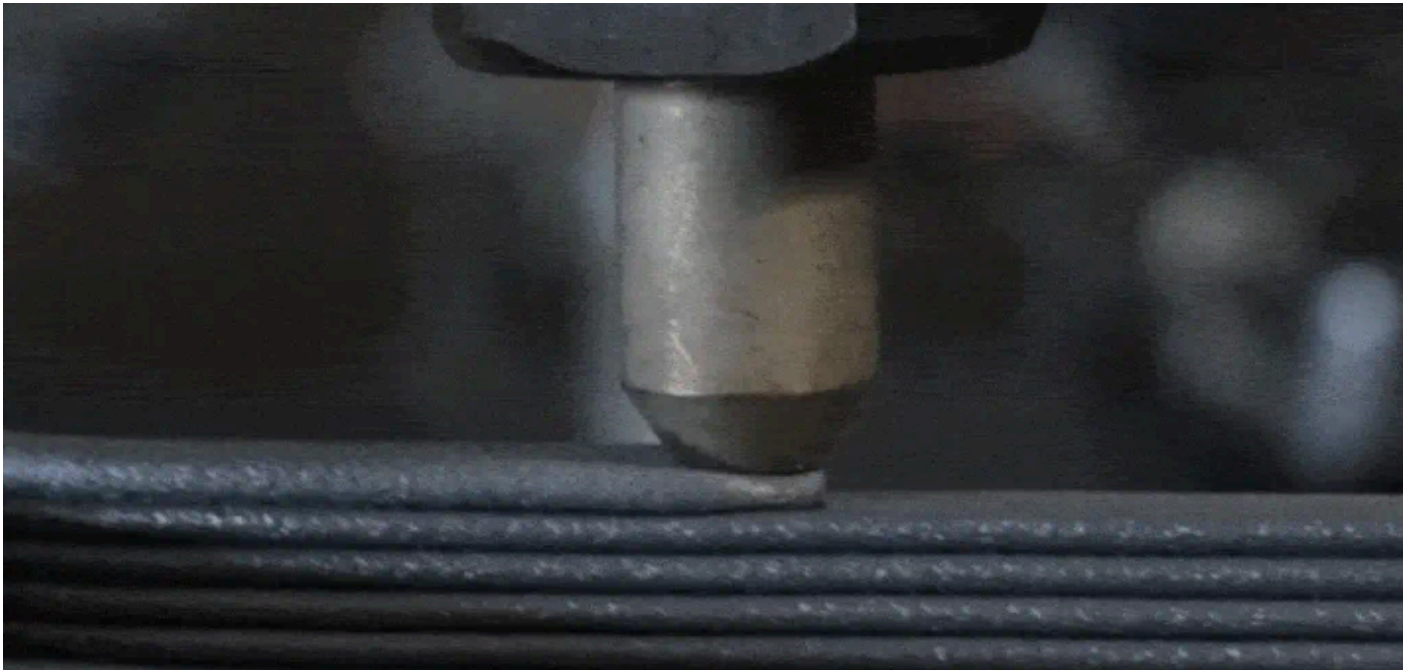

**KR 120 R3900-2 K 1 Robot**

The KR 120 R3900-2 K, optimises performance for additive and subtractive milling, ensuring efficiency, quality, and business future-proofing.

**PE320 Pellet Extruder**

The Rapid Fusion PE-320 Pellet Extruder is a versatile and powerful tool designed for industrial - grade 3D printing.

**Enclosure**

A flexible machine guarding system that's quick to install and always compliant with current standards and directives.

**Modular Heated Bed**

This modular heated build bed system is perfect for those who require large format printing applications.

**Epicurus Controller Pro**

An open-source solution designed to amplify additive manufacturing.

# EXTRUDER-PE320

The Rapid Fusion PE320 Pellet Extruder is a TCT award-winning polymer extrusion tool designed for industrial-grade 3D printing. Weighing just 24 kg, it achieves an impressive extrusion rate of up to 17 kg/h\*.

With powerful heaters and a high-torque motor, the PE320 can handle a wide range of high-temperature engineering materials.

Combining power, precision, and versatility, the PE320 is an excellent choice for upgrading and expanding large-format 3D printing capabilities on existing robot or gantry systems.

\*Extrusion output flow rate tested using 30% Glass-fibre PETG

## KEY FEATURES

### Lightweight, High Material Flow

The PE320 weighs only 24 kg and achieves an extrusion flow rate of up to 17 kg/h, making it suitable for a variety of robot and gantry systems.

### High-Temperature Engineering Polymers

Capable of reaching 450°C, the PE320 can process high-temperature materials like PEI and PEEK, with a nitride-treated tool steel barrel for handling abrasive materials.

### Powerful Motor

The extruder features a 3 kW servo motor and a high-torque 25:1 Schneider Electric gearbox, providing up to 155 Nm of continuous torque for powerful extrusion.

### Precise Temperature Control

Four heating zones with accurate PT100 sensor feedback ensure precise and repeatable temperature control.

### Seamless Integration

The PE320 can be mounted on robot or gantry systems to create large-format 3D printers, easily integrating with the Rapid Fusion Epicurus Controller via the Rapid Fusion Smart Loom.



# EXTRUDER-PE320



Extruder	
Overall Power	5 kW
Extrusion Screw Length	275 mm
Barrel Diameter	35 mm
Overall Length	730 mm
Weight	24 kg
Max. Extrusion Output*	Up to 17 kg/h
Max. Continuous Torque Output	155 Nm
Over-pressure Mitigation**	Rupture Disk 5000 PSI
Material Feed & Part Cooling	Rapid Fusion AirPlus
Nozzle Sizes	3-10 mm

\*\*Rupture Disk can be replaced with melt pressure sensor upon request

Heaters	
Overall Heater Power	2.3 kW
Voltage	4 x 230V AC (1-Ph+N)
Barrel Heaters (Top, Middle & Bottom)	1.65 kW (0.55 kW ea.)
Nozzle Heater	0.65 kW
Max. Temp.	≤ 450°C
Temp. Control*	PWM
Heat Break & Barrel Cooling	Forced air

\*Included in Epicurus Controller

Servo Motor	
Peak Stall Torque	25.1 Nm
Peak Mechanical Speed	6000 RPM
Continuous Torque	6.2 Nm
Continuous Speed	4000 RPM
Gear Ratio	25:1

Servo Drive	
Nominal Output Power	2.7 kW
Voltage	400 / 480 V, 3-phase
Servo Drive*	Lexium 32
Default Control	STEP/DIR signals
Optional Control**	EtherCAT or EtherNet/IP
Servo Drive Feedback***	Modbus RTU

\*Included in Epicurus Controller

\*\*To be specified on purchase

\*\*\*Included in Epicurus Controller PRO

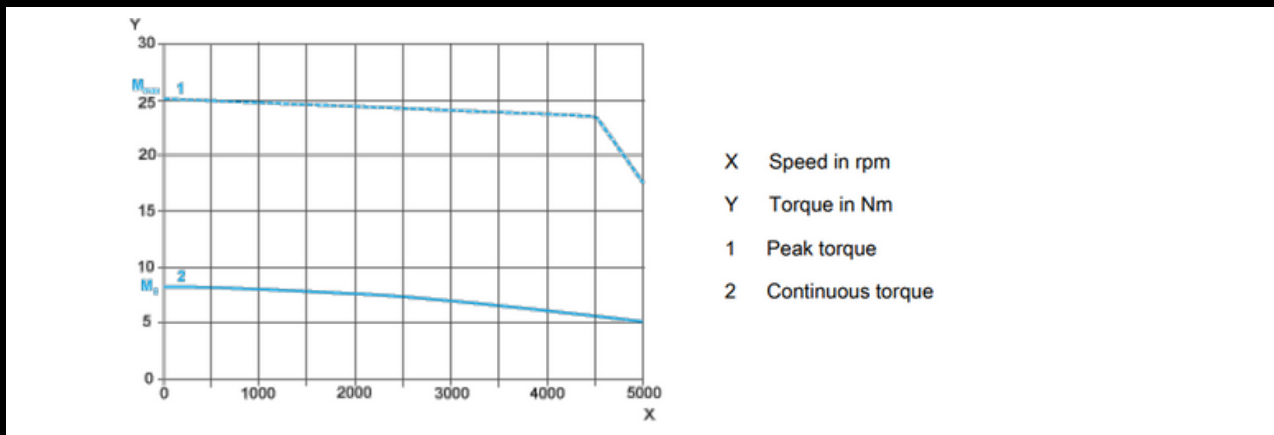

## Safety & Compliance

Rapid Fusion operates under ISO 9001 and ISO 14001 standards, with products meeting BS EN 60204-1 standards. All products come with a 12-month warranty, subject to Terms and Conditions. Please follow all usage guidelines and safety instructions. For more information or queries, please visit our website or contact customer service.

# EPICURUS CONTROL CONSOLE PRO

Introducing the Rapid Fusion Epicurus Controller, a robust open-source 3D printing solution for the Rapid Fusion PE320 Pellet Extruder. It transforms robots or gantry systems into large-format 3D printers with synchronized polymer extrusion, compatible with Kuka and ABB controllers.

## KEY FEATURES

### Product Integration

Integrate the PE320 Pellet Extruder with the Epicurus Controller via the Rapid Fusion Smart Loom for a complete polymer extrusion system. The Epicurus Controller supports up to 4 x 1000 mm x 1000 mm Modular Heated Beds and offers control over material feeding and part cooling through the Rapid Fusion AirPlus.

### Open-source Firmware

The Epicurus Controller uses open-source 3D printer firmware for seamless integration with extruders, robots, or gantry systems, enabling industrial large-format 3D printing.

### Precise Temperature Control

PID temperature control for stable extruder and bed heating ensures high-quality prints.

### Extruder Servo Drive Control

1.8kW servo drive with default internal STEP/DIR signal control and external control via EtherCAT or EtherNet/IP for robot integration.



# KEY FEATURES

## Real-time Monitoring

Monitor extruder temperatures in real-time with a 10-inch full HD touchscreen interface.

## Heating Profiles

Pre-set and customizable material heating profiles for optimal print quality and interlayer bonding accessible via user interface.

## Safety Compliance

Emergency safety functions compliant with BS EN 60204-1 standards, allowing linked emergency stops for the Epicurus Controller and external robot controllers.

## AI Sync PRO

AiSync software automates toolpath generation with visual programming, offering a digital twin feature for build simulation, collision avoidance, and advanced analytics. Integrate video surveillance for real-time monitoring and defect detection. AiSync's machine learning model alerts users to defects, minimizing material waste and saving time.





Functionality	
10" Full HD Touchscreen	✓
Compliant Inter-system Safety	✓
Remote Control	✓
Material Heating Profiles	✓
Temp. Monitoring	✓
Machine Object Model	✓
AiSync Slicing Software	✓
Video Monitoring	✓
Defect Detection	✓
Servo Drive Feedback	✓
Milling Tool Compatible	✓

## USER INTERFACE

**Rapid Fusion PE-320**
⚠ Emergency Stop

Extruder Temperatures
Bed Temperatures
Heating Profiles

Heating Profiles
Reset to Default

Material	Top	Middle	Bottom	Nozzle	Bed	Action
1. Airtech PC-GF	180	250	260	270	100	<span style="background-color: white; color: #9c27b0; padding: 2px 5px; border-radius: 5px;">Set</span>
2. Airtech PP-GF	180	200	200	210	90	<span style="background-color: white; color: #9c27b0; padding: 2px 5px; border-radius: 5px;">Set</span>
3. Airtech ABS-CF	150	190	200	210	100	<span style="background-color: white; color: #9c27b0; padding: 2px 5px; border-radius: 5px;">Set</span>
4. Airtech PETG-GF	150	160	200	205	80	<span style="background-color: white; color: #9c27b0; padding: 2px 5px; border-radius: 5px;">Set</span>
5. Default PETG	80	160	170	180	80	<span style="background-color: white; color: #9c27b0; padding: 2px 5px; border-radius: 5px;">Set</span>
6. Default PLA	80	140	150	160	50	<span style="background-color: white; color: #9c27b0; padding: 2px 5px; border-radius: 5px;">Set</span>

07

# ROBOT SOLUTION –KUKA KR120

Optimised portfolio for maximum flexibility and low total cost of ownership.

The KR QUANTEC portfolio, built on KUKA's decades of automation experience, offers a reliable, versatile, and efficient high-quality solution for your production environment. Customers benefit from a uniquely wide range of applications, with KR QUANTEC robots delivering exceptional performance, cost-effectiveness, and flexibility.



**120 - 300**

Load capacity [kg]



**2671 - 3904**

Reach [mm] (arm length)



## Enhanced Flexibility and Cost Efficiency

A slimmer modular system supplies flexible robots that are tailored to their tasks, ensuring fast delivery times and a low total cost of ownership. This is achieved largely through optimized maintenance and a reduced number of spare parts. The robot portfolio includes the ability to upgrade payloads in the field and deliver optimal process quality through Motion Modes, making the KR QUANTEC a highly flexible machine and securing your future investment in production operations.

### Technical Specifications

Maximum Reach	3904 mm
Rated Payload	120 kg
Maximum Payload	146 kg
Pose Repeatability (ISO 9283)	± 0.05 mm
Number of axes	6
Weight approx.	1280 kg
Maximum Supplementary Load: Rotating Column / link arm / arm	300 kg / 130 kg / 150 kg

### Operating Conditions

Ambient temperature during operation	0°C to 55°C (273 K to 328 K)
--------------------------------------	------------------------------

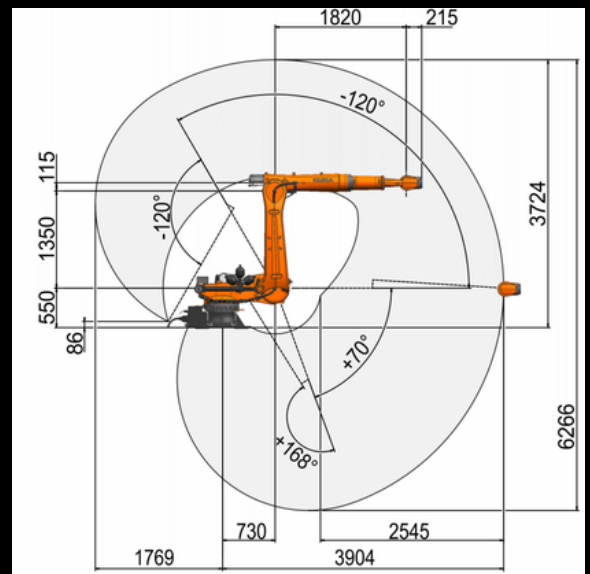

# MODULAR HEATED BEDS— ATLAS HEATED BEDS

The Rapid Fusion 1000 mm x 1000 mm Modular Heated Bed is ideal for large-format 3D printing. It heats to 120°C, providing a flat, precise surface. Features include spring-loaded leveling bolts and adjustable feet. Its modular design allows expansion of the print area. Achieve high-quality, production-level prints with this heated bed.

Technical Specifications	
<b>Print Area (modular)</b>	1000 mm x 1000 mm
<b>Voltage</b>	230V AC (1-Ph+N)
<b>Max. Heater Temp</b>	120°C
<b>Power</b>	4 kW ea.
<b>Stability / Balance</b>	4 x Levelling Feet
<b>Temperature Control</b>	PWM
<b>Frame Material</b>	Powder-coated Steel
<b>Print Bed</b>	10 mm Mill-cast Aluminium
<b>Add-on</b>	Rapid Fusion Fixture Plate

**Example:** 6 connected beds for increased print area



# PELLET DRYER – LABOTEK

The DMR Series offers maximum energy efficiency and flexibility.

This compact dryer provides air flows from 30–90 m<sup>3</sup>/h with a constant dew point of –35°C or better, thanks to its desiccant rotor technology. The rotor's structure ensures large absorbing capacity and no dust emission.

## STANDARD FEATURES

- PLC control
- Desiccant rotor technology supplying constant dew point
- No cooling water and compressed air
- Range of drying temperature 60–140°C
- Labotek Energy Saving System (LESS)
- Drying hopper capacities of 40, 75, 110, 200 and 300 litres
- 3 phase power supply

## OPTIONAL FEATURES

- Conveying units to & from DMR
- Conveying with dry air from DMR (Closed loop)
- Built-in dew point sensor
- High / low temperature version 40–180°C (cooling water needed)
- Tropical execution for high ambient conditions
- Volatile trap



All images & content © Labotek

# SOFTWARE

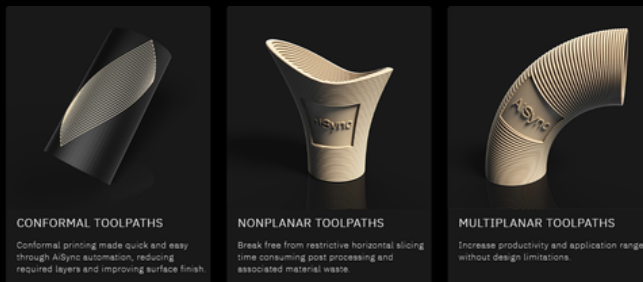
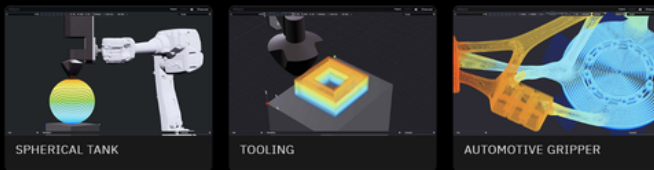

**AI Build** Software AiSync accelerates and automates the creation of even the most advanced, multi-axis toolpaths via a single, intuitive UI. An intelligent AM platform replaces manual coding with visual programming, to completely simplify toolpath generation.

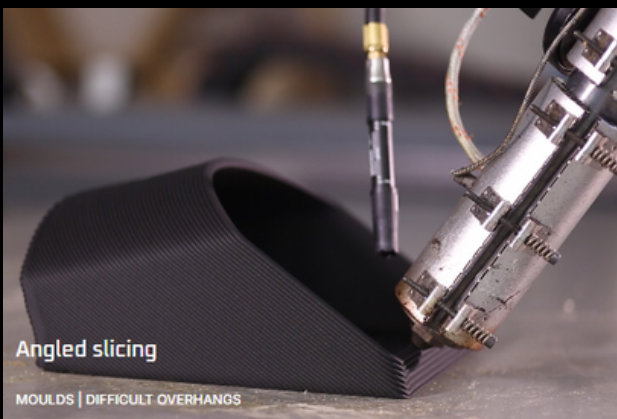

**ADAXIS'** software platform, AdaOne makes it possible to program and control robotic arms as largescale 3D printers for metal, plastics, and concrete. AdaOne covers every aspect going from design to finished part, with optimized support for a wide range of hardware, deposition technologies, and materials.



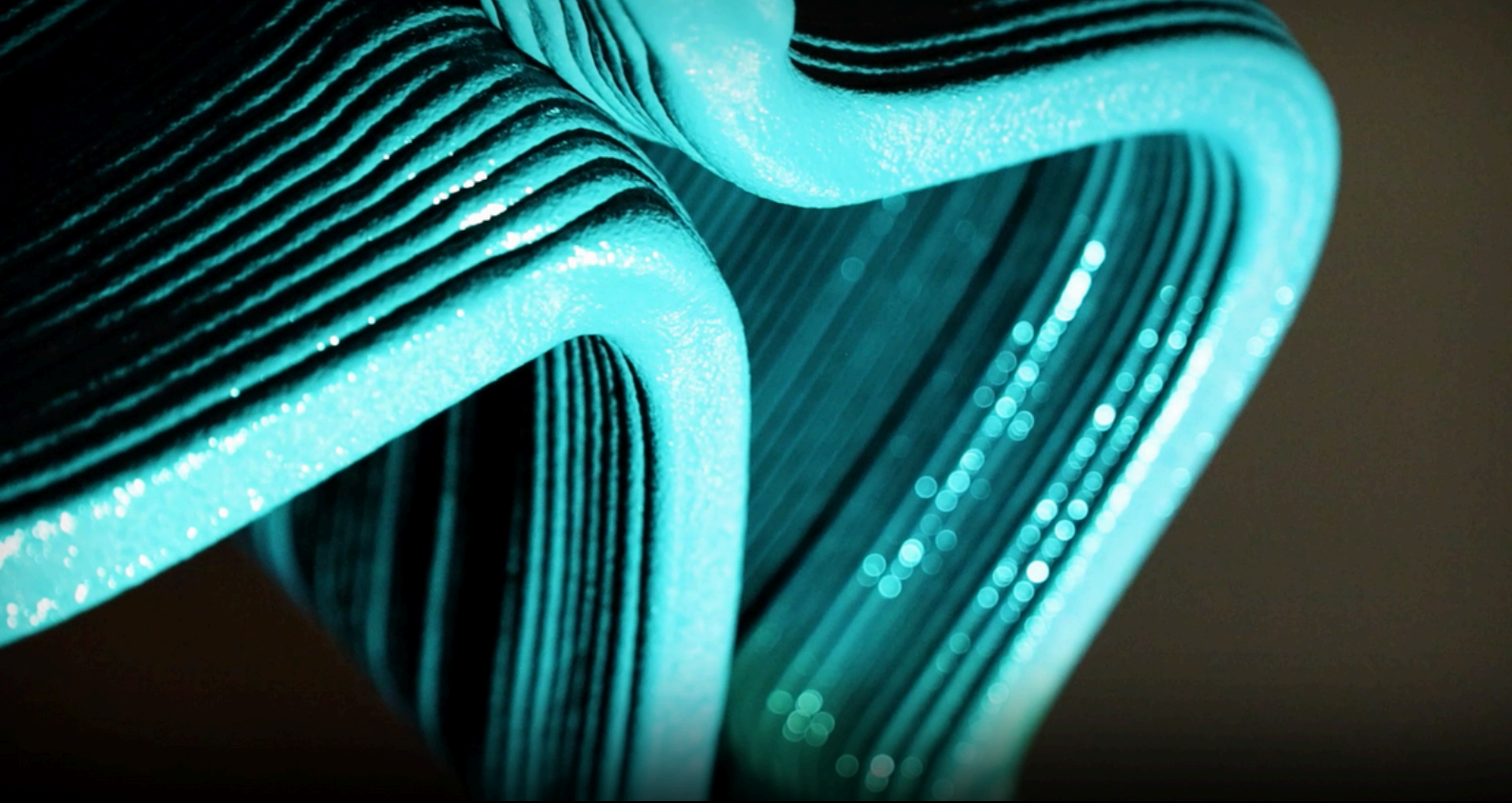

# CONTACT US

Unit 32 De Havilland Road, Dakota Way,  
Skypark, Clyst Honiton, Exeter, EX5 2GE  
rapidfusion.co.uk  
03339398184

**MARTIN WOOD**  
**DIRECTOR OF SALES**

 07866922026

 martin.wood@rapidfusion.co.uk

## Safety & Compliance

Rapid Fusion operates under ISO 9001 and ISO 14001 standards, with products meeting BS EN 60204-1 standards. All products come with a 12-month warranty, subject to Terms and Conditions. Please follow all usage guidelines and safety instructions. For more information or queries, please visit our website or contact customer service.